

DN 200–600 Standard construction

- Valve operated by handwheel
- Non rising spindle
- Material: on request
- Coating: on request
- Flange drilling: see table
- Face-to-face: see table
- Pressure rating: 2.5 bar
- Test pressure acc. to EN 12266-1
- Leakage rate A

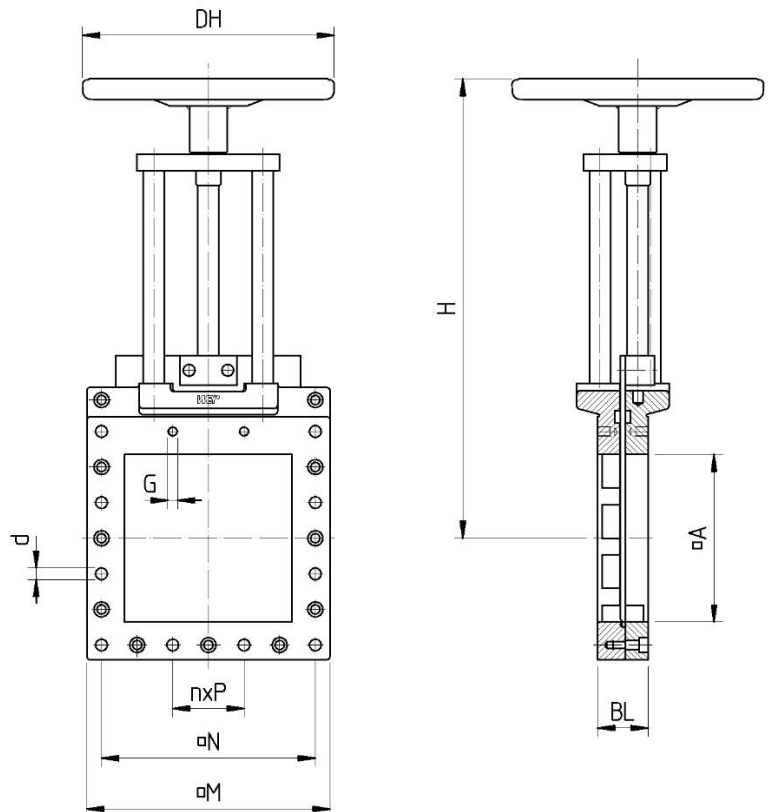

Flange connection

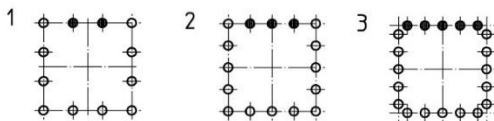

A	BL	H	DH	G	d	M	N	n x P	Flange connection
200	60	549	300	M12	14	290	255	3 x 85	1
250	70	659	300	M16	18	390	330	3 x 110	1
300	70	763	400	M16	18	440	380	4 x 95	2
350	80	846	400	M16	18	490	416	4 x 104	2
400	90	923	400	M20	22	540	480	4 x 96+	3
450	100	1005	500	M20	22	595	550	5 x 110	1
500	110	1083	500	M20	22	650	600	6 x 100	2
600	130	1230	630	M20	22	760	700	7 x 100	1